



**REQUEST FOR PROPOSALS**

**WATER DISTRIBUTION SYSTEM  
NEW CONNECTION AND PIPELINE REPAIRS**

**DUE Tuesday, September 27, 2022 at 4:00 p.m.**

**MIDDLESEX WATER AUTHORITY  
REQUEST FOR PROPOSALS**

**WATER DISTRIBUTION SYSTEM  
NEW CONNECTION AND PIPELINE REPAIRS**

**I. PURPOSE OF REQUEST**

The Middlesex Water Authority is soliciting proposals from interested firms desiring to perform planned water distribution system service installations for new connections and on-call water main repairs for the Middlesex Water Authority (“AUTHORITY”). The AUTHORITY will evaluate proposals from individuals and/or firms for services as defined below.

**II. SCOPE OF WORK**

A. New Connection Service Lines

Provide all labor, material, rolling stock, equipment and traffic control required to access an existing water main to perform a wet tap, saddle, corp-stop, service line, and meter yoke with dual check, and box. Provide all labor, material, rolling stock, equipment and traffic control required to access an existing water meter to install a fire hydrant assembly. New services will be staked on subscriber property by the AUTHORITY (or its representative). A new water meter and meter yoke shall be provided by the AUTHORITY and installed by the Contractor. All other materials to be provided and installed by Contractor. Once installed, the service line shall be flushed and checked for leaks, then cut off at the meter yoke. A Meter Installation Data Sheet shall be completed, including GPS coordinate data, and submitted promptly to the AUTHORITY. The pipeline access area shall be backfilled and compacted in 1-foot lifts until existing grade is obtained. The pipeline access area shall be raked free of any debris or excess dirt. The site shall be seeded with Contractor blend grass seed and covered in straw. Installation will be completed as detailed in the following attachments:

1. Attachment D – Drawing Detail “Water Meter and Box Water Service Lines (for 5/8” through 1” meter installations)”
2. Attachment E – Drawing Detail “Large Water Meter Box (for 1-1/2” through 2” meter installations)”
3. Attachment F – Specification for MWA Water Meter Installations
4. Attachment G – Specification for Piping and Fire Hydrant Installations
5. Attachment H – Drawing Detail “Fire Hydrant”

B. Water Main Repairs

Provide all labor, material, rolling stock, equipment and traffic control required to access a water main and repair a leak. Water main leaks shall be repaired with a wrap-around repair band where possible. Where not possible, the damaged pipe shall be cut out and a section of new pipe shall be sleeved in. Mechanical joints shall be restrained (mega-lug). All fittings and pipe shall be disinfected to AWWA standards prior to installation. Once the repair is made the section of pipe shall be flushed through the closest fire hydrant. The pipeline access area shall be backfilled and compacted in 1-foot lifts until existing grade is obtained.

The pipeline access area shall be raked free of any debris or excess dirt. The site shall be seeded with contractor blend grass seed and covered in straw. Any asphalt or concrete damaged or removed for the purpose of the repair shall be replaced in kind prior to completion of a repair.

C. System Information

Number of Customers	712
Miles of Pipe	42
Pipe Material	C900/HDPE
Pipe Size	2", 4", 6", 8", 10" and 12"
No. of Isolation Valves	Total: 378 (2" – 21; 4" – 33; 6" – 86; 8" – 49; 10" – 16; 12" – 31)
No. of Fire Hydrants	186
No. of Air Relief Valves	Total: 86

**III. TIME**

Upon evaluation of the proposals, the AUTHORITY intends to negotiate contract(s) with qualified firm(s) as soon as practicable during Fall 2022.

**IV. INSTRUCTIONS TO PROPOSERS**

- A. All proposals and/ or questions should be directed to:  
Middlesex Water Authority  
Attention: Jim Nagy, Executive Director  
PO Box 428  
877 General Puller Highway  
Saluda, Virginia 23149  
804-758-4330
- B. All proposals must be in a sealed envelope and clearly marked in the lower left- hand corner: "RFP – Water Distribution System – New Connection and Pipeline Repairs". All proposals must be received in the offices of the AUTHORITY by **Tuesday, September 27, 2022 at 4 pm. Seven (7) copies of the RFP must be presented, in addition to a PDF or Word copy on flash drive or similar device.** No faxed, e-mailed or telephone proposals will be accepted in lieu of paper copy. Late proposals shall be returned unopened.
- C. **Disadvantaged Business Enterprises (small or minority and/or women owned firms)** are encouraged to submit proposals. MBE/WBE firms are encouraged to submit proposals.
- D. **Equal Opportunity Employment Statement:** The AUTHORITY is an Equal Opportunity Employer and will not discriminate on the basis of race, creed, color, national origin, age, or handicap. The provider must certify that he does not, or will not, maintain or provide for his employees any facilities that are segregated on the basis of race, color, creed, or national origin; that he will not discriminate against any employee or applicant for employment because of race, religion, sex, or national origin, except where religion, sex, or national origin is a bona fide occupational qualification reasonably necessary to the normal operation of the provider.
- E. **Compliance with Federal Laws and Rules:** The provider shall comply with the President’s Executive Order #11246 prohibiting discrimination in employment regarding race, color, creed, sex, or national origin; the President’s Executive Orders #12138 and #11625 regarding utilization of MBE/WBE firms; and the Civil Rights Act of 1964.

- F. **Submission Content and Guidelines:** Proposals should be prepared simply and economically, providing a straightforward, concise description of provider capabilities to satisfy the requirements of the request. Special bindings, colored displays, promotional materials, etc. are not required. Emphasis should be on completeness and clarity of content.

**All proposals must be submitted in two component parts proposing the offerors abilities, experience or plan to provide for each of the main submission areas of this RFP, which are as follows:**

1. New Connection Services
2. Repair Services

**Submittals from multiple firms/individuals submitting as a team may be accepted. Awards to multiple offerors may be executed if in the best interest of the Authority.**

**Further, all proposals must be complete** and include the following information signed and notarized as appropriate:

1. Statement of Qualifications (Attachment A)
2. Non-Collusion Affidavit Certificate (Attachment B)
3. Authorization to Submit (Attachment C)

## V. SELECTION CRITERIA.

The AUTHORITY is seeking proposals to provide installation and repair services for its new water system serving the eastern portion of Middlesex County. The offeror should be capable of providing said services for the water system.

The offeror should be capable of providing water line, water meter, fire hydrant installation and other water system appurtenance installation services for the Water Authority in accordance with the latest Hampton Roads Development Standards, applicable American Water Works Association standards and Virginia Department of Health regulations.

The offeror should be capable of providing day to day presence for planned work and emergency, on call repair services to the water system, such as watermain breaks and damaged fire hydrant repair.

The offer should own or have ready access to equipment required to work in the street, at depth below 4 feet, day or night, regardless of weather conditions.

The offeror should be capable of providing 24/7 on call support in case of emergency or after hour repair issues and be located within a reasonable proximity to respond to call for service.

Factor	Weight Given
1. Responsiveness of Proposal to Requirements	10 %
2. References, Experience and Qualifications	30 %
3. Proximity, and assigned staff workload	30 %
4. Costs/Price for service	30 %
<b>Total Criteria Weight</b>	<b>100 %</b>

Each proposal will be independently evaluated on factors 1 through 4 by an evaluation team selected by the AUTHORITY. Selection shall be made of two or more offerors deemed to be fully qualified and best suited among those submitting proposals, on the basis of the factors involved in the Request for Proposal,

including price if so stated in the Request for Proposal. Negotiations shall then be conducted with each of the offerors so selected. The offeror shall state any exception to any liability provisions contained in the Request for Proposal in writing at the beginning of negotiations, and such exceptions shall be considered during negotiation. Price shall be considered, but need not be the sole or primary determining factor. After negotiations have been conducted with each offeror so selected, the public body shall select the offeror which, in its opinion, has made the best proposal and provides the best value, and shall award the contract to that offeror. When the terms and conditions of multiple awards are so provided in the Request for Proposal, awards may be made to more than one offeror. Should the public body determine in writing and in its sole discretion that only one offeror is fully qualified, or that one offeror is clearly more highly qualified than the others under consideration, a contract may be negotiated and awarded to that offeror. A Notice of Intent, indicating the Contractor to be awarded the Contract, will be posted on the Authority website upon determination of such.

## **VI. PROPOSAL TERMS AND CONDITIONS.**

- A. Upon completion of review of offers and notice of award, in accordance with this request and pursuant to Code of Virginia, 1950, as amended, the AUTHORITY will enter into negotiations with the offeror(s) that has best demonstrated the ability to complete the services requested in this RFP.
- B. The AUTHORITY reserves the right to reject any and all proposals, and to waive minor irregularities in any proposal, or to accept the proposal evaluated to be in the best interest of the AUTHORITY.
- C. The AUTHORITY reserves the right to request clarification of information submitted, and to request additional information from any proposer.
- D. The AUTHORITY reserves the right to award any contract to the next most qualified firm, if the most qualified firm does not execute a contract within 45 days of being notified of selection. The AUTHORITY may grant extensions at its sole discretion to allow more time for contract negotiation and development.
- E. The AUTHORITY reserves the right to award a contract based upon single components on any proposal, or to accept one component from one offeror and award another component to another offeror from the proposals evaluated to be in the best interest of the AUTHORITY.
- F. Any proposal may be withdrawn up until the date and time set above for opening of the proposals. Any proposal not so timely withdrawn shall constitute an irrevocable offer, for a period of ninety (90) days to provide to the AUTHORITY the services described in the attached specifications, or until one or more of the proposals have been approved by the Water Authority Board, whichever occurs later.
- G. Any and all contracts resulting from acceptance of a proposal by the AUTHORITY shall be in a form supplied or approved by the AUTHORITY and shall reflect the specifications in this RFP. The AUTHORITY reserves the right to reject any proposed agreement or contract that does not conform to the specifications contained in this RFP and which is not approved by the AUTHORITY Attorney.
- H. The AUTHORITY shall not be responsible for any costs incurred by any offeror or bidder in preparing, submitting, or presenting its response to the RFP.

## **VI. BACKGROUND**

The AUTHORITY has constructed a new 42-mile water system to service areas within the Eastern portions of Middlesex County, from Urbanna to Deltaville. The Water Authority has approximately 712 connections/subscribers, the majority of which are located within the village of Deltaville. The Authority will be installing Kamstrup RF water meters and will be utilizing the associated software to assemble the monthly meter reading data file for export to the billing company. The Middlesex Water Authority is a relatively new entity, created in 2014. It seeks to find the right balance between contracted services and paid staff.

Additional background information regarding the water system is available on the AUTHORITY website: <https://www.co.middlesex.va.us/336/Middlesex-Water-Authority>

The AUTHORITY began operation of portions of the water system in February 2022 and should be operating the system as a whole during Fall 2022.

## **VII. RESULTING CONTRACT**

The successful offeror will be bound by the representations made in its response to the RFP. The Authority intends to award contract(s) for an initial term of three years including an acceptable annual inflation escalation with right to renegotiate and/or renew for an additional three-year period.

## **VIII. OTHER INFORMATION**

For additional information or explanation of the contents or intent of this request, please e-mail, or write your questions to:

Jim Nagy, Executive Director  
Betty Muncy, Administrative Assistant  
Middlesex Water Authority  
PO BOX 428  
Saluda, VA 23149  
804-758-4330  
[j.nagy@co.middlesex.va.us](mailto:j.nagy@co.middlesex.va.us)  
[bmuncy@co.middlesex.va.us](mailto:bmuncy@co.middlesex.va.us)

If requested, the AUTHORITY will provide copies of this document in MS Word format (.doc) to assist with your responses.

## Attachment A

### STATEMENT OF QUALIFICATIONS, EXPERIENCE, AND COMPLIANCE

Proposals for requested services shall be made by including a statement of qualifications, experience and compliance. The firm must have requisite experience in Maintenance Services needed to serve a public water system. The Offeror should address the following criteria:

1. Disclose how many years the company/individual has been in business in Virginia and under what names.
2. Define who will be the staff assigned and project lead for the company. Provide summary of staff members who will be assigned to the work including current and anticipated workload, background and experience, and any specific training, knowledge and experience relating to the repair and maintenance of public water distribution mains, hydrants, service line installation and meters.
3. Describe staff's proximity to Middlesex. It is desired that assigned staff be within a reasonable distance of Middlesex to insure attendance at meetings, timely responses, accuracy of field work and avoidance of potential travel expenses and costs.
4. Provide listing of similar water systems serviced by the firm and/or individuals, including any nearby systems where long-term economies of scale can be achieved. Please provide references with appropriate contact information.
5. Demonstrate any unique approaches, insight or ideas your firm may have with respect to repair and maintenance of water systems and in particular newer public water systems.
6. Describe the company's experience with working within the Hampton Roads design standards.
7. Demonstrate knowledge of codes, regulations or applicable standards as they relate to the repair and maintenance of water distribution systems
8. Disclose any time constraints, obligations on other projects, or any other known circumstances that may adversely affect your company or assigned staff's ability to complete this project successfully in a timely manner.

Each firm submitting a proposal for items included in this RFP shall prepare and submit the following information, signed and notarized, in addition to addressing the qualifications stated above:

1. Name of Firm, Business or Individual
2. Business Address
3. Business Phone, Fax Number and E-mail address
4. Number of years you have been in business in Virginia and under what business names
5. General character of service provided by your firm
6. List the places of operation
7. Commonwealth of Virginia Sales Tax registration and Federal I.R.S. Identification Number.
8. Execute and return this Statement of Qualifications, Attachment B, and Attachment C.

**Attachment A**

I certify that I: (check box as applicable)

\_\_\_ am capable of providing the proposed services as outlined in this proposal;

\_\_\_ will comply with the rules and regulations outlined by the U. S. Code, the Code of Virginia, the Middlesex Water Authority, the Virginia Department of Health, Virginia Department of Environmental Quality, and all rules and regulations of the Commonwealth, and other applicable laws and regulations;

\_\_\_ am an Equal Opportunity Employer and do not discriminate on the basis of race, creed, color, national origin, age, or handicap and certify that the firm does not, or will not, maintain or provide for employees any facilities that are segregated on the basis of race, color, creed, or national origin; and will not discriminate against any employee or applicant for employment because of race, religion, sex, or national origin, except where religion, sex, or national origin is a bona fide occupational qualification reasonably necessary to the normal operation of the Engineer. Further, the firm complies with the President’s Executive Order #11246 prohibiting discrimination in employment regarding race, color, creed, sex, or national origin; the President’s Executive Orders #12138 and #11625 regarding utilization of MBE/WBE firms; and the Civil Rights Act of 1964.

Printed Name: \_\_\_\_\_

Title: \_\_\_\_\_

Signature: \_\_\_\_\_

STATE OF/Commonwealth of \_\_\_\_\_,  
CITY/AUTHORITY OF \_\_\_\_\_, to-wit:

The foregoing Statement of Qualifications, Experience and Compliance was acknowledged before me this \_\_\_\_\_ day of \_\_\_\_\_, 2022, by \_\_\_\_\_

My Commission expires: \_\_\_\_\_ Notary Number: \_\_\_\_\_

\_\_\_\_\_  
Notary Public



## Attachment B

The following certifications are made:

1. The bid or offer (1) is made without prior participation, understanding, agreement, or connection with any corporation, firm or person submitting a bid/offer for the same materials, supplies, equipment, or services with respect to the allocation of the business afforded by or resulting from the acceptance of the bid or proposal, (2) is in all respects fair and without collusion or fraud, and (3) is or is intended to be competitive and free from any collusion with any person, firm or corporation.
2. The offeror has not offered or received any kickback from any other offeror or Contractor, supplier, manufacturer, or subcontractor in connection with the bid/offer on this solicitation. A kickback is defined as an inducement for the award of a contract, subcontracts or order, in the form of any payment, loan, subscription, advance, deposit of money, services or anything, present or promised, unless consideration of substantially equal or greater value is exchanged. Further, no person shall demand or receive any payment, loan, subscription, advance, and deposit of money, services or anything of value in return for an agreement not to compete on a public contract.
3. The offeror is not a party to nor has he participated in nor is obligated or otherwise bound by agreement, arrangement or other understanding with any person, firm or corporation relating to the exchange of information concerning bids, prices, terms or condition upon which the contract resulting from the acceptance of his bid or proposal is to be performed.
4. The offeror understands that collusive bidding is a violation of the Virginia Governmental Frauds Act and federal Law, and can result in fines, prison sentences, and civil damage awards and agrees to abide by all conditions of this proposal.
5. The offeror or subcontractor has not and will not confer on any public employee having official responsibility for a procurement transaction any payment, loan, subscription, advance, deposit of money, services or anything of more than nominal value, present or promised, unless consideration of substantially equal or greater value is exchanged.

**NON-COLLUSION CERTIFICATION**

**Attachment B**

Printed Name: \_\_\_\_\_

Title: \_\_\_\_\_

Signature: \_\_\_\_\_

STATE OF/Commonwealth of \_\_\_\_\_,

CITY/AUTHORITY of \_\_\_\_\_, to-wit:

The foregoing Non Collusion Certification was acknowledged before me this \_\_\_\_\_ day  
of \_\_\_\_\_, 2022, by \_\_\_\_\_

My Commission expires: \_\_\_\_\_

\_\_\_\_\_

Notary Public # \_\_\_\_\_

## Attachment C

The undersigned submits the following proposal desiring to perform the proposed services for the MIDDLESEX WATER AUTHORITY.

Authorization:

\_\_\_\_\_  
Firm Name

\_\_\_\_\_  
Date

\_\_\_\_\_  
Mailing Address

\_\_\_\_\_  
Phone #

\_\_\_\_\_  
State, Zip

\_\_\_\_\_  
Fax #

\_\_\_\_\_  
By (Printed Name)

\_\_\_\_\_  
Title

\_\_\_\_\_  
Signature

\_\_\_\_\_  
Contact Name (if different from above)

\_\_\_\_\_  
Contact Phone #

# Attachment D

## Water Meter and Box Water Service Lines (for 5/8" through 1" meter installations)

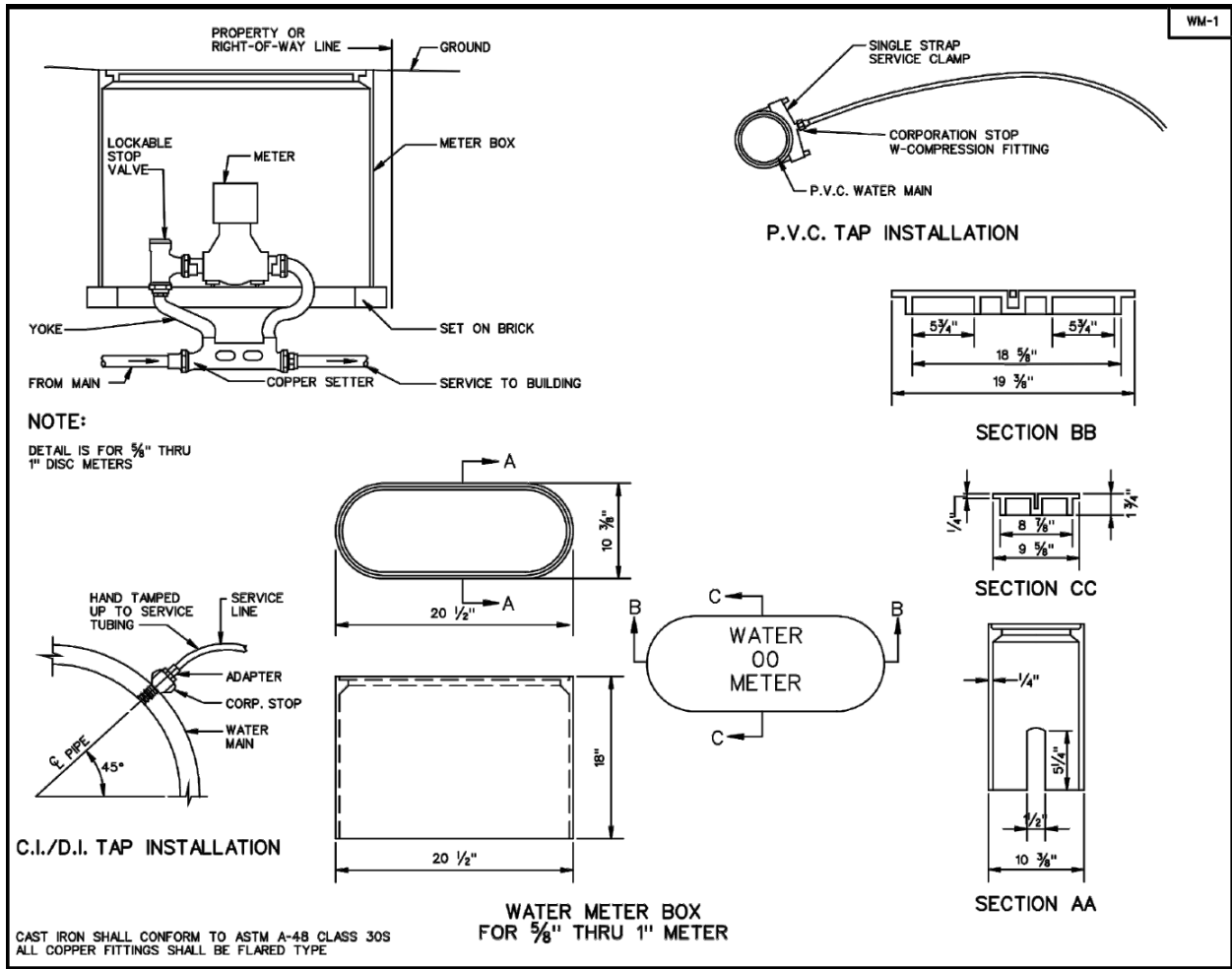

**Attachment E**

Large Water Meter Box” (for 1-1/2” through 2” meter installations)

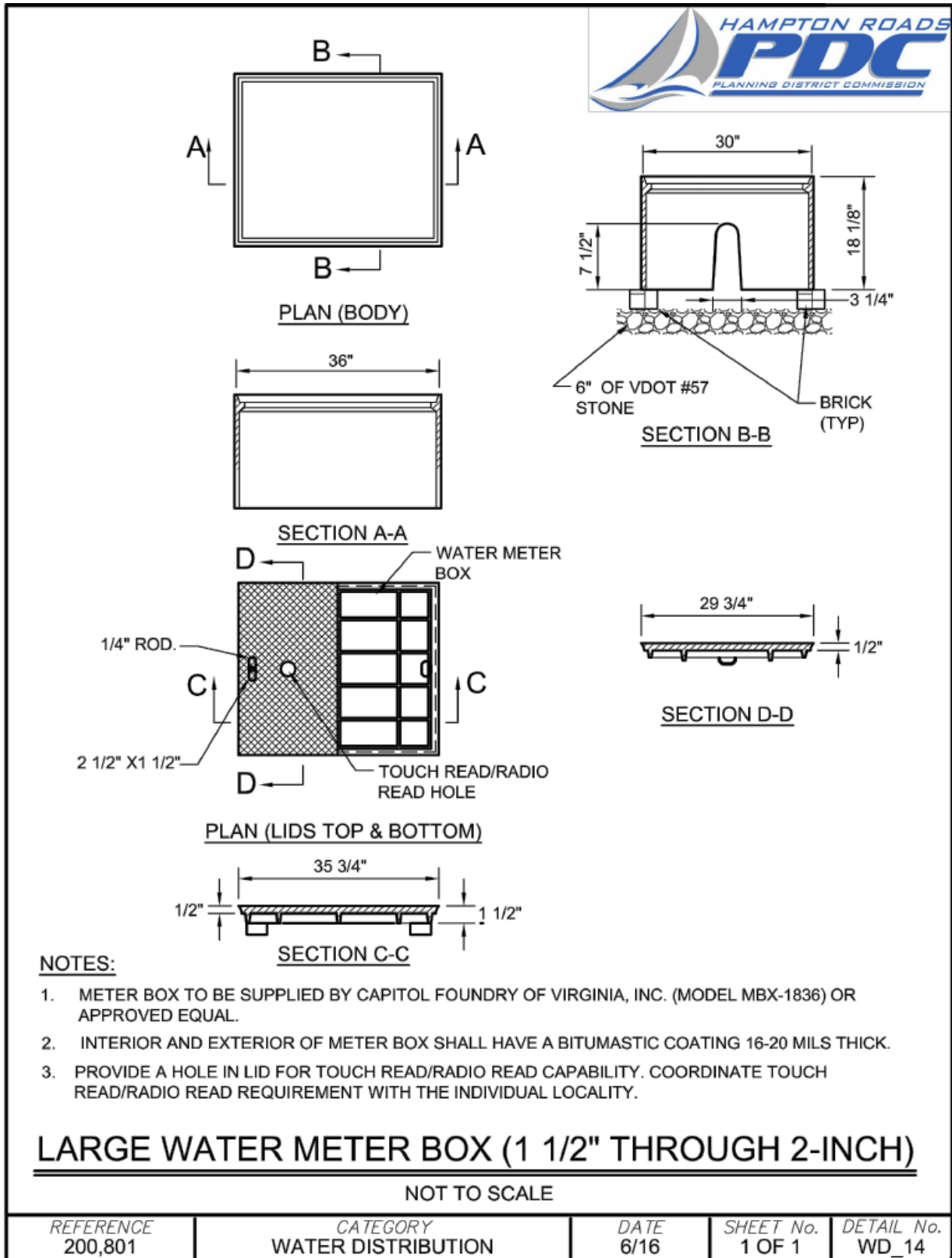

## **Attachment F**

### Specification for MWA Water Meter Installations

#### **I. DESCRIPTION OF WORK**

- A. The intent of this specification is to have the contractor schedule and perform the installation of new meters and associated metering infrastructure. The AUTHORITY utilizes a drive by system engineered by the manufacturer to utilize endpoints with radio controller located at each water meter.
- B. The water meter, meter setter, and vehicle transceiver will be provided to the Contractor by the AUTHORITY at no cost. The water meters are supplied by Fortiline Waterworks and are manufactured by Kamstrup.
- C. The Contractor shall:
  - 1. Furnish all labor, supervision, tools, equipment, supplies and services necessary for the installation of the meter and associated advanced metering infrastructure.
  - 2. Perform construction activities so as to avoid interference with the operation of the water system, and the work of others.
  - 3. Provide for review and approval a list of all pre-construction activities that are to be completed and what support material will be needed for the installation. At a minimum, the following should be performed:
    - a. Notify and Coordinate with the Authority
    - b. Confirm location of water meter
    - c. Testing date.

#### **II. QUALITY ASSURANCE**

- A. Referenced Standards:
  - 1. American National Standards Institute / American Water Works Association:
    - a. C700, Cold Water Meters
  - 2. NSF International Standard / American National Standard:
    - a. NSF/ANSI 61, Drinking Water System Components
- B. Meter Installation Qualifications: Meter installer shall be fully knowledgeable, competent, and experienced, and shall meet the minimum requirement of at least 5 installations within the last 5 years.

#### **III. SUBMITTALS**

- A. Digital Installation Photos: Contractor shall take photos to show site conditions before installation, after installation, and the meter reading / meter number. The photos must show the area around where the work was done including the meter setting before and after. All photos must be provided to the Authority.
- B. Meter Installation Report: Contractor shall prepare and complete a report, in a format provided by the Authority, containing the new meter installation data in addition to any customer information captured including contact information. The report shall include but not limited to:
  - 1. New meter number
  - 2. New meter reading
  - 3. Customer address
  - 4. Leaking plumbing
  - 5. Cross connections
  - 6. Faulty inlet valve
  - 7. Encoder identification number
  - 8. Installers name and identification number
  - 9. Photo numbers

10. Notes (if needed)
11. Customer contact information (if available)
12. Meter GPS data (installed longitude and latitude)

#### IV. PRODUCTS

##### A. The following manufacturers are acceptable:

1. Water Meter Pits or Water Meter Box Manufacturers
  - a. Mueller/Hunt
  - b. Ford Meter Box Company, Inc.
  - c. Or approved equal

#### V. MATERIALS

##### A. Meter Boxes

1. Meters in non-traffic rated areas shall be installed in a Plastic Pit Setter. Pit Setters shall be supplied with a Monitor Cover, which shall have inner lid and tile size of 36" diameter. Installation shall be per HRPDC standard details.
2. Meter boxes install in roadway or drive aisles shall be H20 traffic rated.

#### VI. EXECUTION

##### A. Meter Installation Requirements

1. All water meters and appurtenances shall be installed per manufacturer's recommendation.
2. Meter boxes will be cleared of all water and debris which shall be disposed by the Contractor. Clearance under the meter and couplings shall not be less the 3" to ensure contaminants do not enter the customer piping, the couplings, or meter. Meter spuds and couplings will be sanitized with a sanitary solution of 1-part chlorine and 4-parts water to insure proper sterilization of the meter and open pipes. Once the meter is installed, water is to be restored and the site checked for leaks.
3. Upon completion, the Contractor shall test the water meter and connections for leaks by running water through the system.
4. A complete Meter Installation Report that references all data provided, verified and collected during the execution of each meter installation must be provided for each meter installation.

**Attachment F**  
**Specification for Piping and Fire Hydrant Installations**

**I. GENERAL**

**A. Summary**

This section specifies the requirements for all piping and accessories including all buried and exposed piping.

**B. General Requirements**

1. Piping shall be as follows:
  - a. The water main piping (3-inch or smaller) shall be HDPE DR11.
  - b. The water main piping (4-inch or larger) shall be PVC C900 or HDPE DR11.
  - c. The service line piping shall be HDPE DR11.
2. Taps shall be made to the minimum thread length required under ANSI B16.1-1975.

**II. PRODUCTS**

**A. C900 PVC Pipe and Fittings**

1. Pipe shall be DR11 solid polyvinyl chloride pipe conforming to ANSI/AWWA-C900 rated for 235 psi. Pipe joints shall be bell (conform to ASTM D3139) and gasket (conform to ASTM F477).
2. Fittings shall be mechanical joint ductile iron fittings conforming to AWWA C110-87. Fittings shall have a pressure rating not less than the pressure rating of the pipe.
3. Pipe shall be NSF 61 certified.

**B. High Density Polyethylene Pipe (HDPE)**

1. HDPE pipe shall meet the requirement of ANSI/NSF No. 61 certification.
2. The pipe and fittings shall be molded from PE4710 polyethylene resins in accordance with ASTM D3350 with cell classification of 445574C/E.
3. The pipe shall contain no recycled compounds except those generated in the manufacturer's own plant from resin of the same specification from the same raw material.
4. The pipe shall have a minimum pressure rating of DR 11, DIPS and shall be in accordance with ASTM F714. The pipe nominal size, outside diameter base, material code, dimension ratio, and pressure class shall conform to AWWA C906.
5. The pipe's physical properties shall allow for open-trench and slip-lining installations.
6. Fittings for polyethylene pipe shall be manufactured specifically for the intended use and be approved by the piping manufacturer to be compatible with their product. All fittings shall have a working pressure rating equal to or greater than the pipe and shall meet all requirements of NSF 61.
7. Butt Fusion Fittings shall be PE4710 HDPE, Cell Classification of 445574C/E as determined by ASTM D3350-02 and approved for AWWA use. Butt Fusion Fittings shall have a manufacturing standard of ASTM D3261. Molded and fabricated fittings shall have a pressure rating equal to or greater than the pipe. Fabricated fittings are to be manufactured using Data Loggers. Temperature, fusion pressure, and a graphic representation of the fusion cycle shall be part of the quality control records. All fittings shall be suitable for use as pressure conduits, and per AWWA C906, shall have a nominal burst value of three and one-half times the Working Pressure Rating (WPR).
8. Electrofusion Fittings shall be PE4710 HDPE, Cell Classification of 445574C/E as determined by ASTM D3350-02. Electrofusion Fittings shall have a manufacturing standard of ASTM F1055. Fittings shall have a pressure rating equal to the pipe. All electrofusion fittings shall be suitable for use as pressure conduits, and per AWWA C906, have nominal burst values of three and one-half times the Working Pressure Rating (WPR).



9. Flanged and Mechanical Joint Adapters shall be PE4710 HDPE, Cell Classification of 445574C/E as determined by ASTM D3350-02. Flanged and Mechanical Joint Adapters shall have a manufacturing standard of ASTM D3261.
10. Coupling Style Fitting (for pipe fitting 2-inch and smaller only) may be Dresser style 90 and Ford Meter Products Quick Joint or pack joint fittings or approved equal upon approval of the AUTHORITY.
11. The pipe shall be identified with blue stripe for potable water.
12. HDPE pipe and fitting shall be manufactured by JM Eagle Inc., ISCO Inc., Performance Pipe Inc., or approved equal.

**C. DUCTILE IRON PIPE**

1. Ductile iron pipe shall conform to ANSI/AWWA C115/A21.50 and ANSI/AWWA C151/A21.51 – latest revision, Pressure Class 250 psi. Ductile iron pipe shall also be in accordance with the following requirements:
  - a. Above ground pipe shall have flange joints in accordance with ANSI/AWWA C110/A21.10 and ANSI/AWWA C115/A21.5 – latest revision. Flanged pipe shall be rated for a working pressure of 250 psi.
  - b. The interior of all pipe shall be standard thickness cement lined and seal coated in accordance with ANSI/AWWA C104/A21.4 – latest revision. The exterior of all buried pipe shall be a petroleum asphaltic coating. Coating shall be inspected prior to installation into the trench and all damaged areas shall be repaired in accordance with the manufacturer/s recommendation. The exterior of all non-buried piping shall be shop primed and painted with a mildew resistant coating.
  - c. The weight, class, and casting period shall be shown on each pipe. The manufacturer’s mark, country where cast, year in which the pipe was produced and the letters “DI” or “DUCTILE” shall be cast or stamped on the pipe.
  - d. Ductile iron pipe shall be as manufactured by American Cast Iron Pipe Company, U.S. Pipe and Foundry Company, Inc., Griffin Pipe Products Company, Tyler Pipe Industries or approved equal.

**D. DUCTILE IRON FITTINGS**

1. Fittings shall have a minimum pressure rating not less than 350 psi.
2. Above ground fittings shall have flange joints in accordance with ANSI/AWWA C110/A21.10 with a rated working pressure of 250 psi.
3. The interior of all ductile iron fittings shall be double cement lined and seal coated in accordance with ANSI/AWWA C104/A21.4. The exterior of all non-buried fittings shall be shop primed and painted with a mildew resistant coating.
4. Use of multi-gaskets and spacers are prohibited.
5. Fittings shall have distinctly cast on them the pressure rating, nominal diameter of openings, manufacturer’s identification, country where cast, and the number of degrees or fraction of the circle on all bends. Ductile iron fittings shall have “DI” or “DUCTILE” cast on them.
6. Ductile iron fittings shall be as manufactured by American Cast Iron Pipe Company, U.S. Pipe and Foundry Company, Inc., Griffin Pipe Products Company, Tyler Pipe Industries, or approved equal.

**E. FLANGED COUPLING ADAPTERS**

Adapters shall be Dresser Style 127 or 128, Smith-Blair Type 912 or 913, or equal. Flanged coupling adapters shall be harnessed as specified hereinafter.

**F. JOINT HARNESSING**

Mechanical joint fittings shall be harnessed by using restrained mechanical joints. Restrained mechanical joints shall be megalug by EBAA Iron Inc., American Cast iron Pipe Company Lok-Fast, Clow Corporation Locked Mechanical Joint, or equal.

## G. GATE VALVES

1. Resilient-seated gates valves shall be in accordance with AWWA C509 or AWWA C515 and shall be supplied with an interior epoxy coating in accordance with AWWA C550.
2. Gate valves shall have resilient seats, iron body, non-rising bronze or stainless-steel stem, rubber encapsulated iron disc, O-ring seals, and be suitable for buried service.
3. Gate valves shall be suitable for working pressure up to 250 psi.
4. Valve ends shall be flanged, mechanical joint, or mechanical joint by flange to suit the pipe or fittings.
5. Valve markings shall be cast on the bonnet or body of each valve and shall show the manufacturer's name or mark, year the valve casting was made, the size of the valve, and the designation of working pressure.
6. Gate Valve shall be manufactured by Mueller Co. or approved equal.

## H. CONNECTIONS TO EXISTING SYSTEM

Before the start of the construction, the Contractor shall dig test pits on all the crossings of the connections to the existing system, as applicable, to determine the existing system location, size, and piping material.

## I. FIRE HYDRANTS

Fire Hydrants shall be manufactured by Mueller Co., or approved equal, in full compliance with the AWWA Fire Hydrant Specification C-502 latest revision, NSF 61, NFPA 291, and the following:

1. Type: Compression – Dry Standpipe: Valve shall open against and close with the pressure. The design shall be such that all internal operating parts can be removed through the standpipe and main valve rod extended without excavating.
2. Hydrant shall have a minimum 5-1/4" main valve opening and a minimum inside lower/upper barrel diameter (I.D.) of 7" to assure maximum flow performance. Inlet size and Type: 6" mechanical joint end with accessories.
3. Hose Nozzles: Each hydrant shall be equipped with two 2-1/2" I.D. hose nozzles with National Standard threads, one quarter turn bayonet lock, or threaded in with O-ring seals and suitable locking arrangement.
4. Pumper Nozzle: Each hydrant shall be equipped with on 4-1/2" pumper nozzle having National Standard threads, one quarter turn bayonet lock, or threaded in with O-ring seal and suitable locking arrangement. Pressure loss at 1,000 gpm shall not exceed 3.0 psi through the 4.5" pumper nozzle.
5. Direction of Open: Left, counterclockwise.
6. Size and Shape of Operating Nut and Cap Nuts: To be 1-1/2" point to flat pentagon. Each hydrant shall be equipped with a weather cap.
7. Seal Plate: The hydrant shall be so constructed that a moisture-proof lubricant chamber is provided which encloses the operating threads, thereby automatically lubricating the threads each time the hydrant is operated. The lubricant chamber shall be enclosed with at least three O-rings. The two lower O-rings will serve as pressure seals; the third O-ring will serve as a combined dirt and moisture seal to prevent foreign matter from entering the lubricant chamber. The hydrant shall be equipped with either an anti-friction washer or bronze bushing to reduce operating torque. The bonnet will be secured to the hydrant using bolts and nuts.
8. Standpipe – Groundline Safety Construction: The standpipe sections shall be connected at the groundline by a two-part, bolted safety flange or breakable lugs. The main valve rod sections shall be connected at the groundline by a frangible coupling. The standpipe and groundline safety construction shall be such that the hydrant nozzles can be rotated to any desired position without disassembling and removing the top operating components and the top section of the standpipe. The minimum inside diameter of the standpipe shall be 6".

9. Main Valve, Rod Assembly: The main valve rod assembly shall be so constructed to allow removal of all operating parts through the standpipe regardless of depth of bury, using a removal wrench which does not extend below the ground line of the hydrant. The main valve seat ring shall be bronze, and its assembly into the hydrant shall involve bronze to bronze thread engagement, and the valve assembly pressures seals shall be obtained without the employment of torque compressed gaskets. The design of the main valve rod shall be such the operating threads at the top of the rod and the valve assembly threads at the bottom of the rod are isolated from contact with water in the standpipe or in the hydrant inlet shoe.
10. Drain Valve: The operation of the drain mechanism shall be correlated with the operation of the main valve and shall involve a momentary flushing of the drain ports each time the hydrant is opened. The drain ports shall be fully closed when the hydrant valve is more the 2-1/2 turns open and the drainage channel in the bronze valve seat ring shall connect to two or more drain ports. No springs may be employed in the hydrant valve or drain valve mechanism.
11. Depth of Bury: Normally hydrants shall be suitable for installation in trenches 4-1/2' deep. Required parts and materials to adjust fire hydrants to different depth of bury shall be provided by the manufacturer to meet actual field conditions as required.
12. Paint Instruction: One prime coat and two finish coats shall be factory applied. Finish coats shall be multi-purpose red enamel polyurethane, 1.5 mill dft each. Touch up any damaged areas in the field. The wetted surface of the hydrant shoe shall be epoxy coated to prevent corrosion of the waterway.
13. Pressure Rating: Hydrants shall be rated for 250 psi working pressure and a 500 psi static test pressure.
14. Warranty: Fire hydrants shall be guaranteed to be free from defects in materials for a minimum ten (10) year warranty on material and workmanship. The guarantee must be manufacturer's standard published guarantee. The manufacturing facility for the fire hydrant must have a current ISO certification.

#### J. VALVE BOXES

Valve boxes for buried valves shall be cast iron, screw adjustable shaft boxes with a minimum shaft diameter of 5-1/4 inches. Valve box covers shall be marked with the work "WATER". Valves with valve boxes shall have an extended shaft pinned to the 2" operating nut and terminate 12" below finish grade. Valve box shall have a 24"x24"x6" concrete collar around top of valve box with No. 4 rebar at 6" on center. Valve boxes shall be rated for H2O loading.

#### K. THRUST RESTRAINT

1. A concrete thrust block shall be provided for all 90-degree elbows.
2. All plugs, caps, tees, bends, and pipe joints within the restrained joint lengths shall be restrained with Megalug restraining glands.

### III. EXECUTION

#### A. INSTALLATION

1. Pipe shall be laid to a true, uniform line and grade. Pipe bedding shall be Type 2 – VDOT Standard.

#### B. ERECTION

Piping shall be properly supported, and adequate provision shall be made for expansion, contraction, slope and anchorage. Piping shall be cut accurately for fabrication to measurements established at the construction site. Burr and cutting slag shall be removed by reaming or other cleaning methods. Changes in direction shall be made with fittings.

#### C. DISINFECTION OF WATER SYSTEM PIPING

All new and replacement piping, fittings and materials shall be thoroughly sanitized prior to installation into the system.

# Attachment H

## Fire Hydrant

